

DESIGN OF FAN PERFORMANCE DETECTION SYSTEM BASED ON ARM EMBEDDED SYSTEM

Dr.K.Srinivasan

Department of Electrical and Electronics Engineering, Shadan College of
Engineering and Technology HYD, T.S, INDIA

Received 1, September 2016 | Accepted 25, September 2016

Abstract

The fan performance detect system is based on embedded ARM, and this is an integrated system that detect and analysis the operational status of Fan performance. The detection system for fan energy provides a new technical means. It is realizing the fan system monitor each parameter real-time, reduce the traditional fan testing on the field personnel needs, and improve the fan detection accuracy of various parameters. Thus it is instructive to provide detect data for reference for enterprise's production.

Keywords: embedded ARM, fan performance detect system, real-time monitoring, and fan testing

1. Introduction

In the detection of fan performance, the fan flow (or the wind) is an important index of the fan running status. There are lots of measurement of fan flow methods to choose and the kinds of flow meters are also relatively rich. For example, we can use the thermal mass, rotor flow meter, turbine flow meter, orifice flow meter, uniform tube flow meter, ultrasonic flow meter, waist wheel flow meter, etc. to measuring gas flow rate [1].

1.1. The Detection Method of Fan Performance

First, the performance of fan should be detecting in the normal operation state of the fan crew. Normal operation status refers to the production process of the actual running condition. If the fan is operate under the stable load in long-term, we can think of this condition as normal operation state; within the scope of certain change of Fan load, the most frequent load condition should be regarded as normal running state. In addition, the time of detection continuous time not less than 30 min, each measured parameters measurement frequency should be not less than three times, and take the reading of the arithmetic mean value as calculated value. Detection section should be selected respectively from the fan import not less than five times, export is not less than 10 times the diameter (equivalent diameter) of the straight pipe [2]. The pipe with rectangular cross section use the long side of the multiple to calculate. We can install the straight tube in fan import to measure if the fan is no import line, and no flat long section the dynamic pressure measurement section and static pressure section is not the same cross section. Dynamic pressure measurements should be according to the static pressure measurement section conditions to reduce.

1.2. The Calculation Method of Fan Performance Parameter

1. For circular pipe, the pipe cross section was partitioned into several concentric circles, respectively in the center of circle, concentric circles and pipe horizontal axis, pipe horizontal axis and vertical axis on the intersection of measurement, as shown in Figure 1.

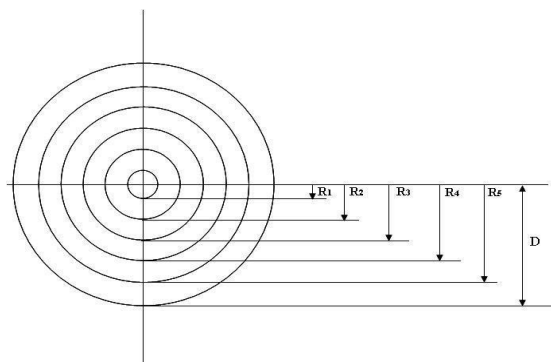

Figure 1. Testing Point Distribution in Circle Pipeline

The distance of concentric circles and the center of circle according to formula (1):

$$R_i = R \sqrt{\frac{2i-1}{2n}} \tag{1}$$

R : pipe radius. i : concentric circles ordinal. n : according to the pipe diameter. Table.1 is determine the number of concentric circles.

Table 1. Relationship between Diameter and Number of Concentric Circle

Diameter of Pipe D/mm	300	400	600	800	1000	1200	1400	1600	1800
The quantity of concentric circles (n)	3	4	5	6	7	8	9	10	11

2. The total pressure measurement of fan. Using pit tube and micro differential pressure to measuring each point static pressure and dynamic pressure.

According to formula (2) to calculate section average static pressure:

$$P_j = \frac{1}{m} \sum_{i=1}^m P_{ji} \tag{2}$$

P_j : The average static pressure of measurement section. P_{ji} : The measurement section on the measuring point pressure. m : The measurement section on the number of measuring point.

3. The measurement section of average dynamic pressure according to formula (3) :

$$P_d = \sqrt{\frac{1}{m} \sum_{i=1}^m (P_{di})^2} \tag{3}$$

P_d : The average static pressure of measurement section. P_{di} : The measurement section on the measuring point pressure. m : The measurement section on the number of measuring point.

4. According to formula (4) calculate fan total pressure:

$$P = (P_{j2} + P_{d2}) - (P_{j1} + P_{d1}) \tag{4}$$

P : Full pressure of fan. P_{j2} : The measurement section average static pressure of fan export. P_{d2} : The measurement section average dynamic pressure of fan export. P_{j1} : The measurement section average static pressure of fan inlet. P_{d1} : The measurement section average dynamic pressure of fan export.

5. The measurement of flow detect of gas density. With a large barometer and thermometer measure atmospheric pressure and gas temperature, according to formula (5) to calculate gas density:

$$\rho = \rho_0 \frac{273}{273 + t} \frac{p_k + p_i}{101325} \quad (5)$$

ρ : Standard state of the gas density. T : Point section in gas temperature. p_h : Measurement when atmosphere. p_i : Average static pressure of flow detect point.

6. The calculation of motor load rate. Motor load rate (β) according to formula (6) to calculate:

$$\beta = \frac{P_2}{P_n} \quad (6)$$

H_j : the energy utilization rate of fan unit. P_{yp} : The output power of fan unit effective. P_1 : motor input power.

2. The Design of System Hardware

2.1. Core Modules Design

To the fan detect analysis system based on the design of the function, the system hardware is mainly composed of five parts that is core board, motherboard, wind speed and temperature acquisition, export and entry static pressure acquisition, and RS232 communication module. The core processor chip of this system is Samsung S3C2440A, and this processor is integrated rich internal equipment. It gives overall development to fan detect analysis system of and brought great convenience.

The chip adopted Advanced Micro controller Bus Architecture. The central processor is based on the ARM920T processor RISC instruction, the data cache and instruction cache are 16 KB, it isn't need other on the configuration of modules Basically, and it is very suitable for

development that have greater restrictions cost and hand-held devices that more sensitive on power consumption[3]. The whole system framework as shown in Figure 2.

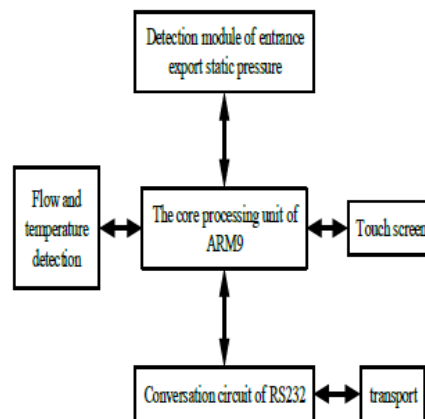

Figure 2. The Framework of the Whole System

This system composes with two layer circuit board on instrument onboard. Because the motherboard module are low speed equipment so there are two circuit boards, and they can better operate on the main board. There has no influence to the system overall performance. Main board structure as shown in Figure 3 below.

4. Test Results and Analysis

After test and analysis of fan performance system, We make the wind speed comparison test in testing process, and the standard wind tunnel of contrast test at wind speed in 30 m/s - 20 m/s within the accuracy grade 1.5%, within the 20 m/s - 3 m/s, the accuracy grade is 1.0%. In order to study the system measurement error. Wind velocity contrast results as shown Figure 7.

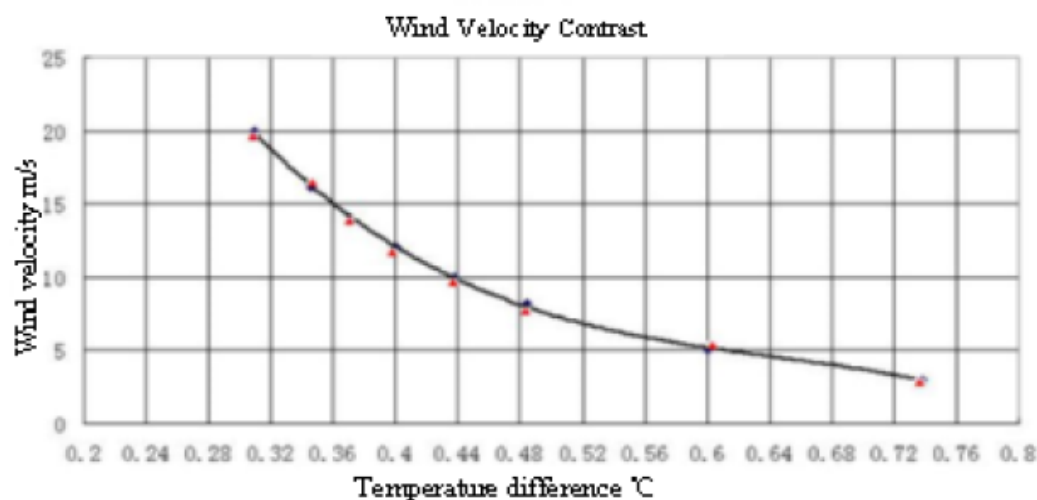

Figure 7. Arranging Diagram of Testing System

Before the wind test that adopts thermal flow meter, we must install "measurement integration device of temperature and pressure "on exhaust pipeline. In the fan non-stop state, the device can be successfully installed in 30 minutes. The test is completed this device can be convenient to take off, and the whole testing engineering convenient and quick.

References

- [1] D. Boling, "Programming Microsoft Windows CE.NET", Microsoft press, (2003), pp. 20-23.
- [2] C.-Hong, "Embedded Linux Remote Control System to Achieve to the Stereo Image", Springer Berlin/Heiderg, vol. 7, no. 345, (2006), pp. 521-526.
- [3] K. Raj, "Embedded Systems: Architecture, Programming and Design", McGraw-Hill Education, (2005), pp. 2-10.
- [4] G. Henkelman, G. Johannesson and H. Jónsson, "Theoretical Methods in Condensed Phase Chemistry", edited by S.D. Schwartz, volume 5 of Progress in Theoretical Chemistry and Physics, chapter, 10, Kluwer Academic Publishers, (2000).
- [5] A. Carullo, S. Corbelline, A. Luoni and A. Neri, "A calibrator for heterogeneous acquisition system application to a photovoltaic plant", Proc. IEEE Int. Instrum. Meas. Technol. Conf, (2009), pp. 406.